

# CHEETAH

## RUGGEDIZED CAMERA SERIES

### C2420Y/Z CMOS 5 MP with Polarization Filters Camera Link®



#### Imperx: C2420Y/Z

The CLF-C2420Y/Z camera features the Sony Pregius IMX250MZR micro-polarized CMOS sensor with a native resolution of 2464 x 2056 in a 2/3" optical format delivering up to 97 frames per second with a Camera Link® Full Power over Camera Link (PoCL®) output. The sensor is available in monochrome (Z) or color (Y) versions and has a unique 2x2 pixel sub-array where each pixel within the sub-array senses a different polarization angle (0, 45, 90 or 135 degrees). This allows the user to obtain images with four different polarization angles in each image capture. The camera allows the user to select and view images from each polarization angle or save raw image files with all four polarization angles. The C2420Y/Z's flexibility, outstanding sensitivity, and speed make it suitable for a broad range of applications from reducing glare off glass, water, and painted surfaces to materials science or 3D image reconstruction.

#### Specifications

Feature	Description	Feature	Description
Output Interface	Camera Link® Base, Medium, Full with Power over Camera Link (PoCL)	Strobe Output	2 strobes, programmable position and duration
Resolution	2464 (H) x 2056 (V) 1232 (H) x 1028 (V) per polarization angle	Pulse Generator	Yes, programmable
Sensor	Sony Pregius IMX250M CMOS color (Y) or monochrome (Z)	Data Correction	4 LUTs pre-programmed with Gamma 0.45; Bad pixel correction (static, dynamic)
Sensor Format	8.4 mm (H) x 7.1 mm (V), 2/3" optical format	Lens Mount	C-Mount (default)
Pixel Size	3.45 microns square	P-Iris	Optional
Shutter	Global shutter (GS)	P-Iris Control	Auto, programmable
Digitization	8, 10, 12-bit	Supply Voltage Range	12V DC (5V – 30V), 1.5 A inrush
Frame Rate	97 fps (8-bit), 79 fps (10-bit), 67 fps (12-bit)	Camera Current	Typical: 200 mA/12V
Dynamic Range	71dB	PoCL Capable	Yes, in Base/Medium/Full mode
Output Bit Depth	8, 10, 12-bit	Size - Width/Height/Length	37 mm (W) x 37 mm (H) x 48.6 mm (L)
Analog/Digital Gain	Manual, Auto; 0 dB – 48 dB, 480 steps	Weight	91.8 g
Digital Gain	1x (0 dB) to 4x (12 dB) with a precision of 0.001x	Vibration, Shock	TBD
Black Level Offset	Manual (0 – 255), Auto	Environmental	-30 °C to +75 °C
White Balance	Manual, Auto, Off	Humidity	10% to 90% non-condensing
Shutter Speed	1 µs/step, 14 µs to 16.0 s	MTBF	TBD
Exposure Control	Off, Manual, External, Auto	Military Standard	MIL-STD-810G
Regions of Interest (ROI)	2 ROI	Regulatory	FCC Part 15, CE, RoHS
Polarization Angles	0, 45, 90, and 135 degrees		
Trigger Inputs	External, Pulse generator, Software, Computer		
Trigger Options	Edge, Pulse width, Trigger filter, Trigger delay, Debounce		
Trigger Modes	Free run, Standard, Fast		
External Inputs/Outputs	2 IN (OPTO, LVTTTL) / 2 OUT (OPTO, TTL)		

## Imperx: C2420Y/Z Applications

The CLF-C2420Y/Z incorporates a number of unique features tailored to reduce system complexity, maximize interface bandwidth, and expand the usable operational range.

Aerospace • Satellites • Surveillance • Ball Grid Array • Printed Circuit Board Inspection • Motion Analysis • Broadcast Television Telepresence • Unmanned Aerial Vehicles • Machine Vision • Intelligent Traffic Systems • Aerial Imaging • Open Road Tolling Systems • Situational Awareness

## Absolute Quantum Efficiency

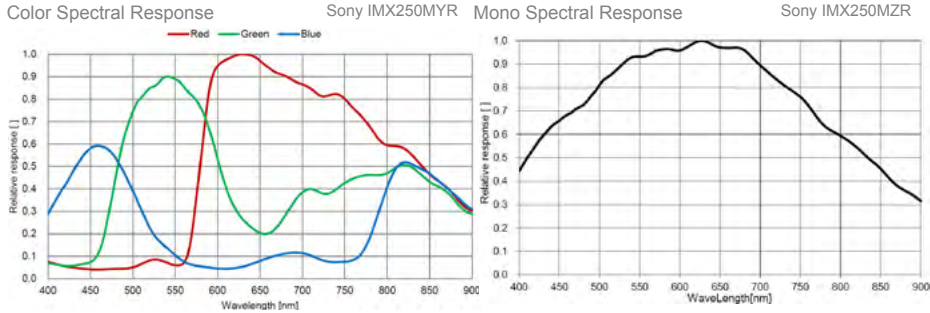

## Dimensions

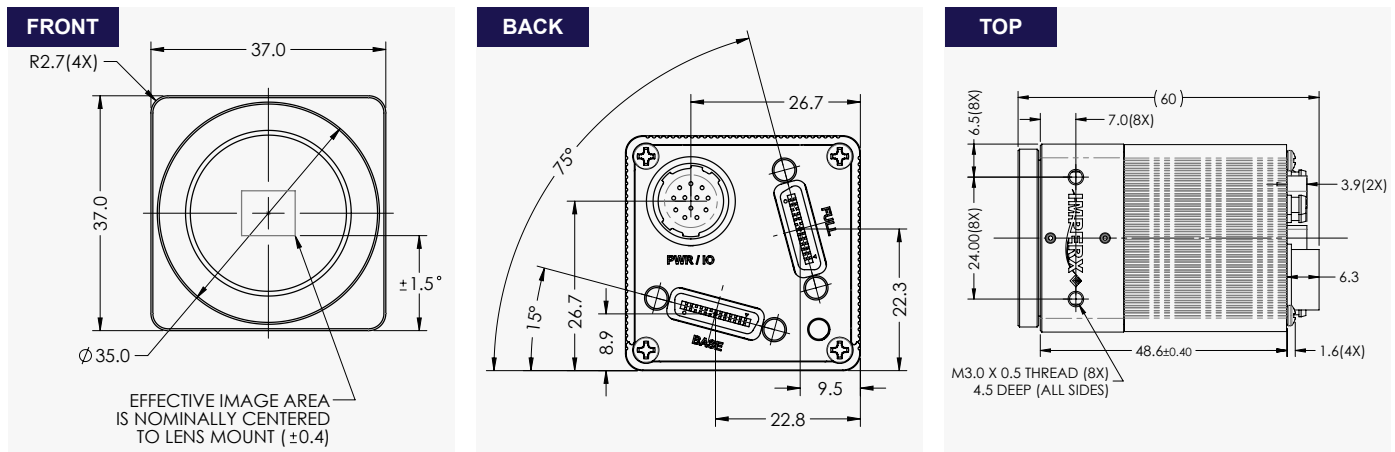

## Ordering Information

<b>Output Interface</b>
Camera Link® Full (CLF) w/PoCL®
<b>Sensor Types available</b>
C2420Z = Monochrome
C2420Y = Color

<b>Lens Mounts</b>
C-Mount (Default)
P-Iris (Optional)
<b>Accessories (Sold separately)</b>
PS12V04A-Power Supply w/ 1 input and 1 output

## Software/Drivers/Interface



## Hirose Connectors

<b>Power and I/O Interface</b>	
	<ul style="list-style-type: none"> <li>1. 12 VDC Return</li> <li>2. +12 VDC</li> <li>3. Reserved</li> <li>4. Reserved</li> <li>5. OUT2 RTN (OPTO)</li> <li>6. OUT1 RTN</li> <li>7. OUT1 (TTL)</li> <li>8. IN1 (OPTO)</li> <li>9. IN2 (LVTTTL)</li> <li>10. IN1 RTN</li> <li>11. IN2 RTN</li> <li>12. OUT2 (OPTO)</li> </ul>

Rev: cl\_c2420Y/Z\_r2\_2019

Quality Management System ISO 9001:2015 Registered  
 Environmental Management System ISO 14001:2015 Registered  
 DDTC Registered (Directorate of Defense Trade Controls, US Department of State)



IMPERX 6421 Congress Ave., Boca Raton, FL 33487, USA  
 Tel: +1-561-989-0006. Email: sales@imperx.com

WWW.IMPERX.COM

Technical data has been fully checked, but accuracy of printed matter is not guaranteed. Subject to change without notice. Copyright 2019.