

CHEETAH

RUGGEDIZED CAMERA SERIES

C5440 CMOS 17 MP 10G GigE Vision®



PRELIMINARY

Imperx: C5440

The 10G-C5440 camera features the Sony Pregius IMX387 Global Shutter CMOS sensor with a native resolution of 5472 x 3084 in a 4/3" optical format. The Gen<I>Cam™ compliant camera delivers up to 70 frames per second in global shutter mode using the GigE Vision® standard interface. The Sony Pregius image sensor delivers outstanding sensitivity and excellent image quality. Imperx puts you in control by providing full access to raw data without corrections. Using the simple intuitive graphical user interface, you can quickly apply image corrections, if desired. The C5440's flexibility, image quality, and speed make it suitable for a broad range of diverse and demanding applications, but "one size doesn't fit all," and Imperx can help optimize the camera to your exact requirements.

Specifications

Feature	Description	Feature	Description
Output Interface	10G GigE Vision®	Strobe Output	2 strobes, programmable position and duration
Resolution	5472 (H) x 3084 (V)	Pulse Generator	Yes, programmable
Sensor	Sony Pregius IMX387 CMOS Color/Mono	Data Correction	4 LUTs pre-programmed with Gamma 0.45; Bad pixel correction (static, dynamic), Flat field correction
Sensor Format	18.8 mm (H) x 10.6 mm (V), 4/3" optical format	Lens Mount	F-Mount (default)
Pixel Size	3.45 microns square	Canon EF-Mount	Optional, Active or Passive
Shutter	Global shutter (GS)	Supply Voltage Range	12 VDC (5 V – 30 V), 1.5 A inrush
Sensor Digitization	8, 10, 12-bit	Camera Current	Typical: 320 mA/12 V (EST)
Frame Rate	70 fps (8-bit), 35 fps (10-bit/12-bit unpacked), 46 fps (10-bit/12-bit packed)	Power Consumption	Typical: 3.8 W (EST)
Dynamic Range	71 dB	PoE Capable	Yes
Output Bit Depth	8, 10, 12-bit	Size - Width/Height/Length	60 mm (W) x 60 mm (H) x 59.5 mm (L) (EST)
Analog/Digital Gain	Manual, Auto; 0 dB – 48 dB, 480 steps	Weight	TBD
Digital Gain	1x (0 dB) to 4x (12 dB) with a precision of 0.001x	Vibration, Shock	20G/100G
AEC/AGC	Yes	Environmental	-30 °C to +75 °C Operating, -40 °C to +85 °C Storage
Black Level Offset	Manual (0 – 255), Auto	Humidity	10% to 90% non-condensing
White Balance	Manual, Auto, Once, Off	MTBF	TBD
Shutter Speed	1 µs/step, 30 µs to 16.0 s	Military Standard	MIL-STD-810G
Exposure Control	Off, Internal, External, Auto	Regulatory	FCC Part 15 Class A, CE, RoHS
Regions of Interest (ROI)	2 ROI		
Binning	1 x 2, 2 x 1, 2 x 2		
Sub-sampling	1 x 2, 2 x 1, 2 x 2		
Trigger Inputs	External, Pulse generator, Software		
Trigger Options	Edge, Pulse width, Trigger filter, Trigger delay, Debounce		
Trigger Modes	Free run, Standard, Fast		
External Inputs/Outputs	2 IN (OPTO, LVTTTL) / 2 OUT (OPTO, TTL)		

Imperx: C5440 Applications

The 10G-C5440 incorporates a number of unique features tailored to reduce system complexity, maximize interface bandwidth, and expand the usable operational range.

Aerospace • Satellites • Surveillance • Ball Grid Array • Printed Circuit Board Inspection • Motion Analysis • Broadcast Television • Telepresence • Unmanned Aerial Vehicles • Machine Vision • Intelligent Traffic Systems • Aerial Imaging • Open Road Tolling Systems • Situational Awareness

Absolute Quantum Efficiency

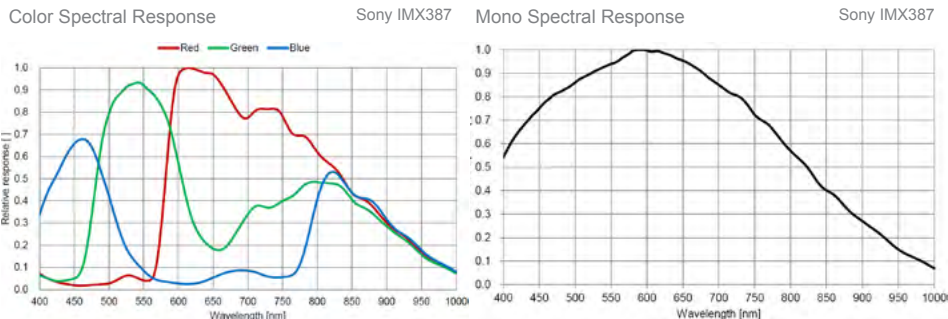

Dimensions

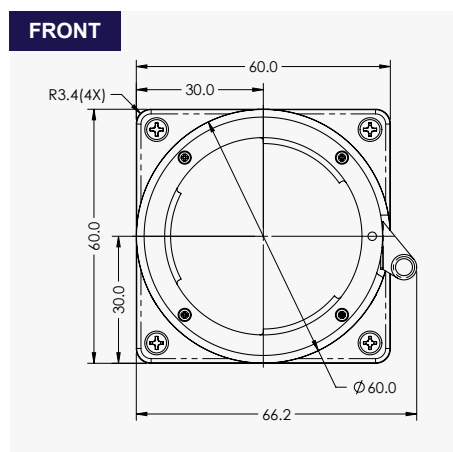

Ordering Information

Output Interface
10G GigE Vision® (10G)
Sensor Types available
Monochrome
Bayer Color

Lens Mounts
F Mount (Default)
M42 (Optional)
Canon EF Mount (Optional)
Accessories (Sold separately)
PS12V04A-Power Supply w/ 1 input and 1 output

Gen<I>Cam Compliant Camera Configurator

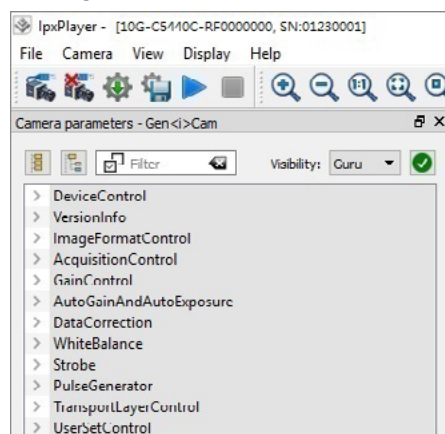

Hirose Connectors

Power and I/O Interface	
	<ol style="list-style-type: none"> 12 VDC Return +12V DC Reserved Reserved OUT2 RTN (OPTO) OUT1 RTN OUT1 (TTL) IN1 (OPTO) IN2 (LVTTTL) IN1 RTN IN2 RTN OUT2 (OPTO)

Connector: Hirose HR 10A-10R-12PB(71)

Rev: 10g_c5440_r2_2019

Quality Management System ISO 9001:2015 Registered
 Environmental Management System ISO 14001:2015 Registered
 DDTC Registered (Directorate of Defense Trade Controls, US Department of State)



IMPERX 6421 Congress Ave., Boca Raton, FL 33487, USA
 Tel: +1-561-989-0006. Email: sales@imperx.com

WWW.IMPERX.COM

Technical data has been fully checked, but accuracy of printed matter is not guaranteed. Subject to change without notice. Copyright 2019.