

CHEETAH

RUGGEDIZED CAMERA SERIES

C2410 CMOS 5 MP

GigE Vision® with Power over Ethernet (PoE)



Imperx: C2410

The POE-C2410 camera features the Sony Pregius IMX264 Global Shutter CMOS sensor with a native resolution of 2464 x 2056 in a 2/3" optical format delivering up to 22 frames per second with GigE Vision® Power over Ethernet (PoE) output. The Sony Pregius image sensor delivers outstanding sensitivity and excellent image quality. Imperx puts you in control by providing full access to raw data without corrections. Using the simple intuitive graphical user interface, you can quickly apply image corrections, if desired. The C2410's flexibility, image quality, and speed make it suitable for a broad range of diverse and demanding applications, but "one size doesn't fit all," and Imperx can help optimize the camera to your exact requirements.

Specifications

Feature	Description	Feature	Description
Output Interface	GigE Vision® with Power over Ethernet (PoE)	Strobe Output	2 strobes, programmable position and duration
Resolution	2464 (H) x 2056 (V)	Pulse Generator	Yes, programmable
Sensor	Sony Pregius IMX264 CMOS Color/Mono	Data Correction	4 LUTs pre-programmed with Gamma 0.45; Bad pixel correction (static, dynamic), Flat field correction
Sensor Format	8.5 mm (H) x 7.1 mm (V), 2/3" optical format	Lens Mount	C-Mount (default)
Pixel Size	3.45 microns square	P-Iris	Optional
Shutter	Global shutter (GS)	P-Iris Control	Auto, Programmable
Sensor Digitization	12-bit	Supply Voltage Range	12 V DC (6 V – 30 V), 1.5 A inrush
Frame Rate	22 fps (8-bit), 11 fps (10-bit/12-bit unpacked), 15 fps (10-bit/12-bit packed)	Power Consumption	Typical: 3.24 W
Dynamic Range	71 dB	Camera Current	Typical: 270 mA @ 12 V
Output Bit Depth	8, 10, 12-bit	PoE Capable	Yes
Analog/Digital Gain	Manual, Auto; 0 dB – 48 dB, 480 steps	Size - Width/Height/Length	37 mm (W) x 37 mm (H) x 61.5 mm (L)
Digital Gain	1x (0 dB) to 4x (12 dB) with a precision of 0.001x	Weight	113.2 g
Black Level Offset	Manual (0 – 255), Auto	Vibration, Shock	20G (20 – 200 Hz XYZ)/100G
White Balance	Manual, Auto, Once, Off	Environmental	-30 °C to +75 °C Operating (-40 °C to +85 °C tested) -40 °C to +85 °C Storage
Shutter Speed	1 µs/step, 14 µs to 16.0 s	Humidity	10% to 90% non-condensing
Exposure Control	Off, Manual, Auto, External	MTBF	TBD
Regions of Interest (ROI)	2 ROI	Military Standard	MIL-STD-810G
Sub-sampling	1x2, 2x1, 2x2	Regulatory	FCC Part 15, CE, RoHS
Trigger Inputs	External, Pulse Generator, Software		
Trigger Options	Edge, Pulse width, Trigger filter, Trigger delay, Debounce		
Trigger Modes	Free run, Standard, Fast		
External Inputs/Outputs	2 IN (OPTO, LVTTTL) / 2 OUT (OPTO, TTL)		

Imperx: C2410 Applications

The POE-C2410 incorporates a number of unique features tailored to reduce system complexity, maximize interface bandwidth, and expand the usable operational range.

Aerospace • Satellites • Surveillance • Ball Grid Array • Printed Circuit Board Inspection • Motion Analysis • Broadcast Television • Telepresence • Unmanned Aerial Vehicles • Machine Vision • Intelligent Traffic Systems • Aerial Imaging • Open Road Tolling Systems • Situational Awareness

Absolute Quantum Efficiency

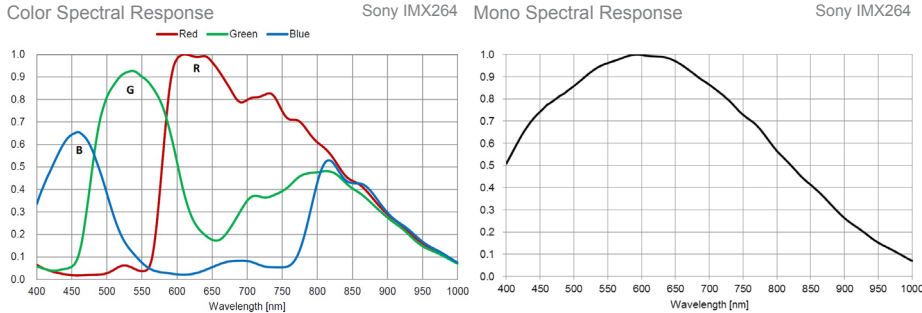

Dimensions

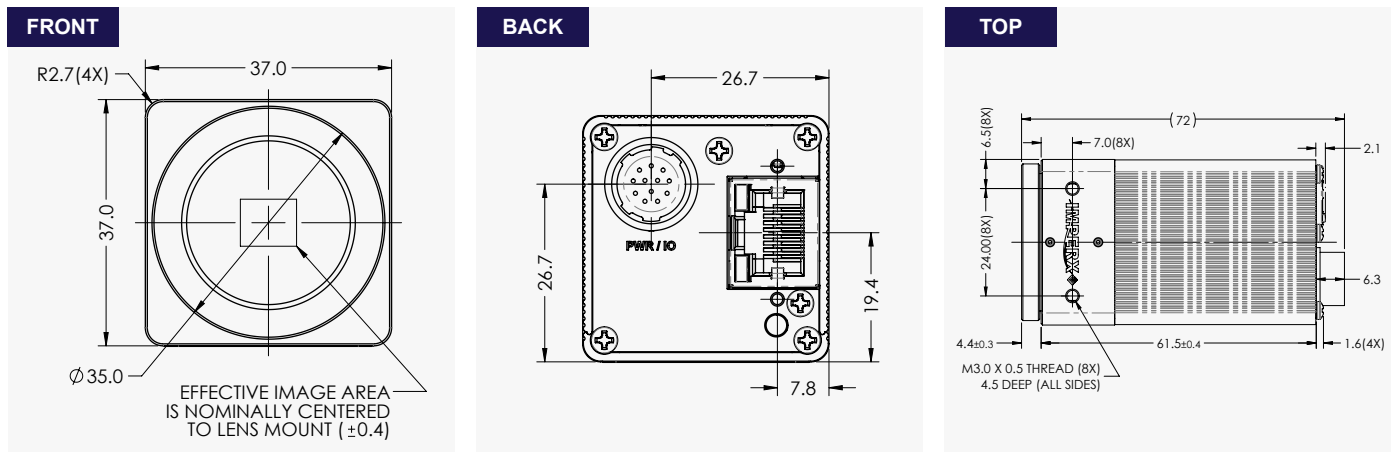

Ordering Information

Output Interface GiGE Vision® with Power over Ethernet (PoE®)	Lens Mounts C-Mount (Default) P-Iris (Optional)
Sensor Types available Monochrome Bayer Color	Accessories (Sold separately) PS12V04A-Power Supply w/ 1 input and 1 output

Gen<I>Cam Compliant Camera Configurator

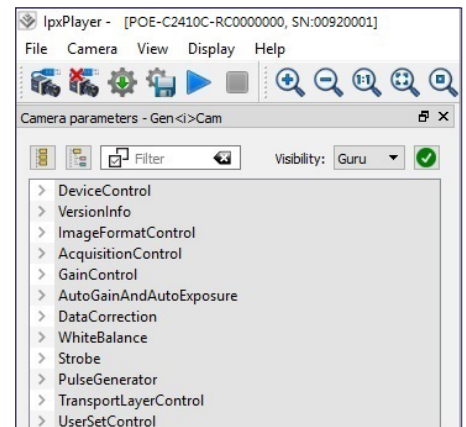

Hirose Connectors

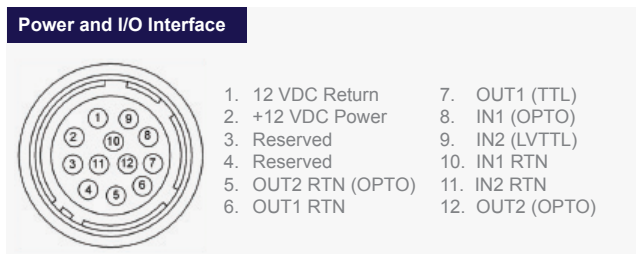

Connector: Hirose HR10A-10R-12PB(71)

Rev: poe_c2410_r3_2019

Quality Management System ISO 9001:2015 Registered
Environmental Management System ISO 14001:2015 Registered
DDTC Registered (Directorate of Defense Trade Controls, US Department of State)



IMPERX 6421 Congress Ave., Boca Raton, FL 33487, USA
Tel: +1-561-989-0006. Email: sales@imperx.com

WWW.IMPERX.COM

Technical data has been fully checked, but accuracy of printed matter is not guaranteed. Subject to change without notice. Copyright 2019.

